

● For SVGA Panel

External view (dimension : W150mm * H130mm)

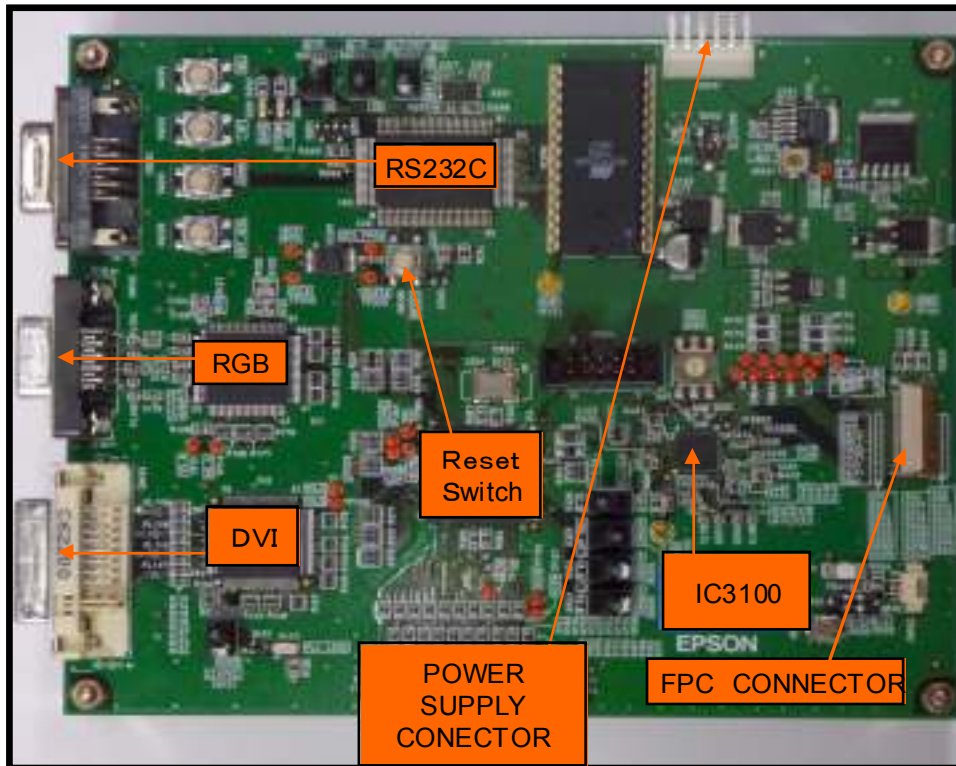

IC Block Diagram

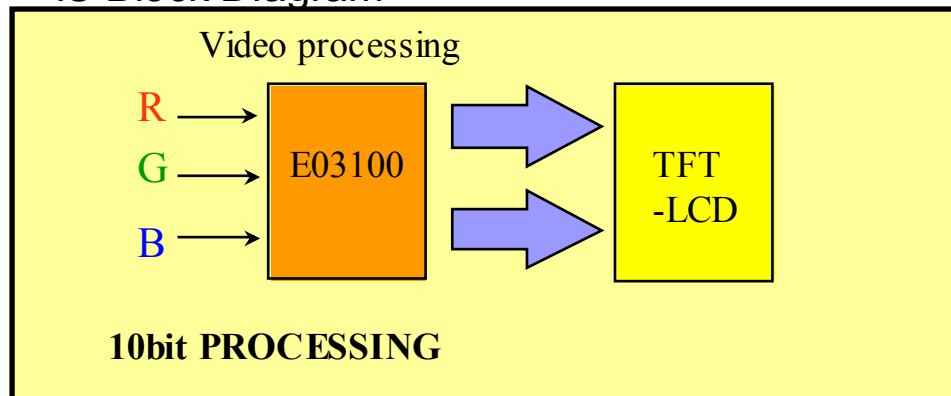

- 1) Evaluation board is accompanied by the following documents.
"instruction book", "config file (a sheet of FD)"
- 2) LCD Panel is not attached. Please purchase it separately.
- 3) Extra preparation by customer
 - a. DC stabilized power supply
 - b. Video signal source (Analog RGB/DVI)
 - c. RS232C cable (for configuration)

Usage notice

- a. Information in these documents is subject to be changed without notice.
- b. None of the documents contained herein may be copied or reprinted, whether in full or in part, without prior notice.
- c. Mentioned contents of the document were described as of October 2009.

<Contact>

©SEIKO EPSON CORPORATION 2009

TFT Business Planning Group

TFT Business Planning Department

421-8 Hino, Hino-shi, Tokyo-to 191-8501 JAPAN

TEL 042-587-5447 FAX 042-587-5115

<http://www.epson.jp/device/https>